

Technical specifications

Diesel Generator Set

QIS 35

Voltage: 400/230 V

Frequency: 50HZ



Genset Image for illustration purposes only

TECHNICAL INFORMATION

| | | |
|-------------------------------|-----------|----------------------|
| Standby Power (ESP) | kVA | 33 |
| | kW | 26 |
| Prime Power (PRP) | kVA | 30 |
| | kW | 24 |
| Mechanical structure | | Soundproofed |
| Engine | | KUBOTA V3300-BG |
| Alternator | | MECC ALTE ECP28-VL/4 |
| Control card | | DEEP SEA 4620 |
| Measures (L x W x H) | mm | 2.220 x 940 x 1.185 |
| Empty weight | kg | 930 |
| Fuel tank | L | 105 |
| Acoustic pressure, LpA | dB(A) a 7 | 63 |
| Acoustic power LwA | dB(A) | 90 |

| Voltages | Prime Power (PRP) | | Standby Power (ESP) | |
|----------|-------------------|------|---------------------|------|
| | (kVA) | (kW) | (kVA) | (kW) |
| 380/220 | | | | |
| 400/230 | 30 | 24 | 33 | 26 |
| 415/240 | 30 | 24 | 33 | 26 |

Notes:

PRIME POWER: Electrical power data available at a variable load without limits of hours per year. An overload of 10 % is allowed for 1 hour of every 12. In accordance with ISO 8528/1 (2005) – PRP

STANDBY POWER: Electrical power data at variable load in an emergency in accordance with standard ISO 8528/1 (2005) – ESP. Overloads of emergency power are not allowed.

The standard reference conditions are: 25 °C, 100 kPa and 30% relative humidity. Gasoil density: 0.85 g/cm3. Gasoline density: 0.68 g/cm3.

INDEX

General description

Engine

Alternator

Bedplate

Soundproofed canopy

Electric Panel

ATS

Dimensions and Weight

Performance class

Regulation

Annex: Drawings

GENERAL DESCRIPTION

Specifically developed for the industrial applications, this stationary soundproof generator set is easy to use and straightforward to maintain. The available features & options are designed to fully meet the requirements of all industrial applications. The generator set will automatically start on mains failure and cool down and stop as soon as the mains come back. The generator set also controls the load transfer between mains (utility) and generator set. It can also be start-up by means of an external signal. It's your solution for Predictable Power.

ENGINE

| | | | |
|-------------------------|----------|--------------------------------|------------|
| Engine brand | KUBOTA | Engine Capacity (c.c.) | 3.300 |
| Model | V3300-BG | Bore (mm) | 98 |
| R.P.M. | 1.500 | Stroke (mm) | 110 |
| Net power (kWm) | 30 | Compression ratio | 22,6:1 |
| Fuel | Diesel | Type of regulation | Electronic |
| No. of cylinders | 4 L | Europe exhaust emission | EU3A |

Cooling System

The cooling system consists of a radiator, expansion tank, water pump, engine-driven cooling fan and thermostat, all of them original from the engine manufacturer.

It is cooling the engine block thanks to a pressurized forced-circulation of 50/50 mixture of Ethylene Glycol anti-freeze.

All the rotating parts are protected.

| | | | |
|---|-------|---------------------------------------|------|
| Flow of air from fan (m³/min) | 43 | Coolant capacity (l) | 13,2 |
| Cooling type | Water | Limit ambient temperature (°C) | 50 |

Lubrication System

| | | | |
|-------------------------|----|---|-----|
| Oil capacity (l) | 13 | Maximum oil consumption (% fuel consumption) | 0,0 |
|-------------------------|----|---|-----|

Air intake system

D1105-BG2- D1703M-BG-V2403M-BG-V3300DI

The air intake system for combustion consists of heavy duty air filter (dual stage filter and safety cartridge) and air restriction indicator, original from the engine manufacturer.

| | |
|--|-----|
| Intake air flow (m³/min) | 2,2 |
|--|-----|

Exhaust System

The exhaust system consists of pipes, bellow, interior and exterior aluminized steel exhaust silencer that is highly resistant to corrosion, rain cap and hot part protections.

| | | | |
|--|-----|----------------------------|-----|
| T^a gas emission (°C) | 375 | Inlet diameter (") | 2,4 |
| Gas flow (m³/min) | 5,9 | Body diameter (mm) | 280 |
| Maximum exhaust back pressure (kPa) | 3,6 | Exhaust length (mm) | 776 |
| Number of exhaust | 1 | Atenuattion (dB(A)) | 26 |
| Outlet diameter (") | 2,4 | | |

Start system

Start system that uses an electrical motor, battery and battery charge alternator that is driven by the engine itself. The start motor and the battery charge alternator are originals from the engine manufacturer.

| | |
|---------------------|---------------------|
| Battery type | 1 x 12V 74Ah - 680A |
|---------------------|---------------------|

Fuel supply system

The fuel system consists of a fuel tank, feed pump, water separator fuel filter including 30 microns filtering element, injection pump and injection nozzles.

The fuel tank is made from plastic to prevent rust and includes a filling connection with cap and key, a cleaning hatch and draining plug for easier maintenance. The fuel level is controlled thanks to a fuel level sensor with an analogue gauge mounted in the control cubicle.

| | |
|-------------------------------|-----|
| Fuel tank capacity (L) | 105 |
|-------------------------------|-----|

Fuel consumption panel (range according to the standard configuration)

| Load | Prime Power (PRP) | | Standby Power (ESP) | |
|------|-------------------|-----------|---------------------|-----------|
| | (l/h) | Range (h) | (l/h) | Range (h) |
| 25% | 2,9 | 36 | | |
| 50% | 3,9 | 27 | | |
| 75% | 5,7 | 18,4 | | |
| 100% | 7 | 15 | 7,7 | 13,6 |

ALTERNATOR

Mecc Alte alternator with 4 poles, with a lifetime lasting greased bearing, H class insulation, without brushes, 2/3 coil and AVR (Automatic Voltage Regulator)

Protection of all the windings by means of 2-part high quality polyester resin impregnation. The stator windings receive a double impregnation and the rotor exciter receives an additional coat of EG43 varnish.

Excitation system with MAUX auxiliary winding with overload capacity 3 times the nominal current for 20 s.

Joining of engine and alternator through flexible disc coupling.

Regulations:

- CEI 2-3
- IEC 34-1
- EN 60034-1
- VDE 0530
- BS 4999-5000
- CAN/CSA-C22.2 No14-68-No100-95
- ISO 8528:3

Low wave distribution:

- THD < 4%
- THD < 4%
- THF (IEC) < 2%
- TIF (NEMA) < 45

Incorporates electromagnetic emissions suppressor in accordance with standard VDE 0875, class K.

| | | | |
|-------------------------------|---------------------|--|-----|
| Brand | MECC ALTE | Voltage Stability | ±1% |
| Model | ECP28-VL/4 | Performance at 75% p.f. 0.8 (%) | 89 |
| Alternator Power (kVA) | 33 / Standby (SB27) | Performance at 100% p.f. 0.8 (%) | 88 |
| Number of wires | 12 | Direct subtransient reactance X"d (%) | 8,8 |
| IP Alternator | IP 23 | Subtransient time constant, T"d (ms) | 12 |
| Excitation system | MAUX | Zero sequence reactance, Xo (%) | 2,8 |
| AVR model | DSR | Short-circuit ratio, Kcc | 0,6 |

▪BEDPLATE

The engine-alternator set is coupled to the bedplate by means of anti-vibration shock mounts that absorb almost all the vibrations.

The base frame is made of a phosphate, passivated steel profile with polyester dust paint that guarantees a resistance of up to 480 hours in a saline mist chamber in accordance with standard ASM B-117-09.

The base frame is able to hold 100% of the liquids of the genset, reducing any potential environmental impact. It has a drainage plug.

▪SOUNDPROOFED CANOPY

Soundproof generator set by means of galvanized, phosphate steel, passivated and finish using polyester dust paint that guarantees a resistance of at least 720 hours in a saline mist chamber in accordance with standard ASM B-117-09.

The canopy includes an external access to the lifting beam and push to close latches with key. The lifting beam is available as an option.

It is lined inside with a noise-absorbing material of polyurethane foam with a 30 mm thick waterproof protector veil with a density of 25 kg/m³.

It also has an emergency shutdown pushbutton that is accessible from the outside.

▪ELECTRIC PANEL

Easily accessed control cubicle integrated in the generator set with digital controller providing advanced engine monitoring and protection features. Performance and maintenance requirements can also be observed. The cubicle includes multi-poles thermal-magnetic protection circuit breaker against overloads and short-circuits.

Easily accessed control cubicle integrated in the generator set with digital controller providing advanced engine monitoring and protection features. Performance and maintenance requirements can also be observed. The cubicle includes multi-poles thermal-magnetic protection circuit breaker against overloads and short-circuits.

| | | | |
|--|--------|------------------------|-------------------|
| Circuit Breaker rated current (A) | 50A 4P | Battery charger | DSE 9150 - 12V 2A |
|--|--------|------------------------|-------------------|

An electronic battery charger is available as an option.

It is designed to be permanently connected to the battery and maintains it charged to its maximum capacity. The charger includes reverse polarity protection, short circuit protection and current limiting, and it automatically returns to float mode when charging is complete.

Control Card

DEEP SEA control plate, DSE 4620 with grid monitor that starts-up the generator set when it detects a failure in the electrical power supply from the grid and sends a signal to the switching panel to switch from the grid position to the group position. Once the power supply has been re-established, it sends an order to the switching panel to transfer the generator set power to the grid and shuts-down the generator set once it has cooled down. It also starts-up the generator set using an external signal.

Also, control plate DSE 4620 checks a large number of parameters of the generator set which allows it to display information, statuses and alarms. If required, it will shutdown the generator set: Due to high coolant fluid temperature, low oil pressure, low coolant fluid level, etc.

Includes a LCD screen with lighting, 2 navigation menu buttons, independent operational mode buttons, and alarms and status indicating LEDs.

Communications via USB, and Completely configurable using a PC in Windows environment and free Scada type software in real time.

Includes reading and displaying of parameters with RMS values, real time clock, events history log up to 15 events and programming of alarms, events, start-ups and shutdowns.

Operating modes: START-UP, SHUTDOWN, AUTO, MANUAL AND TEST.

Generator

- Generator voltage (L-N)
- Generator voltage (L-L)
- Generator frequency
- Generator current
- kW
- kVA
- kWh
- kVAh
- Power factor

Grid

- Grid voltage (L-N)
- Grid voltage (L-L)
- Grid frequency

Engine

- Turn speed
- Cooling fluid temperature
- Oil pressure
- Hour meter
- Battery voltage
- No. of start-ups
- Fuel level

Protections

- Start-up fault (generator set shutdown)
- High coolant temperature (alarm and generator set shutdown)
- Low oil pressure (alarm and generator set shutdown)
- Low fuel level (alarm)
- Low cooling fluid level (generator set shutdown)
- Overload (alarm and generator set shutdown)
- Battery voltage high (alarm)
- Battery voltage low (alarm)
- Battery charge alternator failure (alarm)
- Generator low frequency (alarm and shutdown)
- Generator high frequency (alarm and shutdown)
- Generator low voltage (alarm and shutdown)
- Generator high voltage (alarm and shutdown)
- External emergency shutdown (shutdown)
- Engine overspeed (shutdown)
- Maintenance interval (alarm)



■ATS

Optional Cabinet for switching between the grid and the generator set by means of Schneider brand contactors with an integrated mechanical and electrical interlocking device.

High dynamic resistance against short-circuits. Stable positions not affected by the changes in voltage and mechanical vibrations. IP66 protection. Connections: Lower/lower.

| | |
|------------|------------------------|
| ATS | 4P 60A 230-240V L-N CC |
|------------|------------------------|

■DIMENSIONS AND WEIGHT

| | |
|-----------------------|-------|
| Length, L (mm) | 2.220 |
| Width, A (mm) | 940 |
| Height, H (mm) | 1.185 |
| Weight (kg) | 930 |

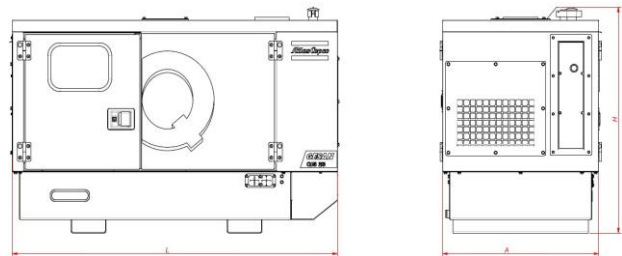

■PERFORMANCE CLASS

Execution class in accordance with ISO 8528/5 (2005) taking into account the behaviour of the generator set in a permanent mode of operation with different load levels, as well as in a temporary mode of operation due to shocks in the load.

| | |
|--------------------------|----|
| Performance class | G2 |
|--------------------------|----|

■REGULATION

The generator set has a CE Marking that includes the following directives:

- 2006/42/EC Machine Safety.
- 2006/95/EC Low Voltage.
- 2004/108/EC Electromagnetic compatibility.
- 97/68/EC Gases and contaminating particles emissions.
- 2005/88/EC Noise emissions of machines outdoors in soundproof generator sets.

Applicable international regulations:

- ISO 8528
- ISO 3046
- BS 5000
- IEC 60034

ISOMETRIC VIEW (1 : 20)

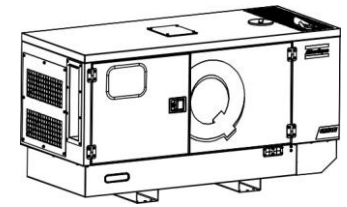

Service Pan
Cleaning Co,

| | |
|-----|---|
| | 1 |
| | 1 |
| 880 | 1 |
| 865 | 1 |

Noise Label

Entry for
Power Cables

Fuel tank drain

2200 186,611
External Fuel Tank
connections (EFT)

940 137,01]

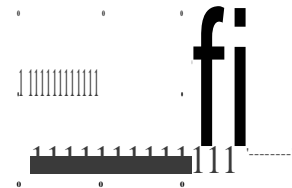

1

MAINTENANCE SPACE (1 : 15)



D 1



--L-- R865

Service Door for
Filling Coller

b

250 [9,84]

1:1:

275110,83]

Note:

Dimensions are in inches.

All material is subject to change without notice. See the latest revision for details.

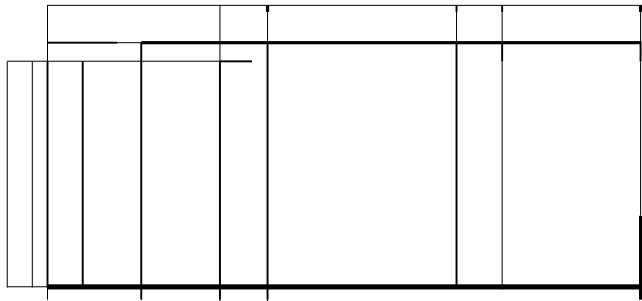

... : :
m | : :

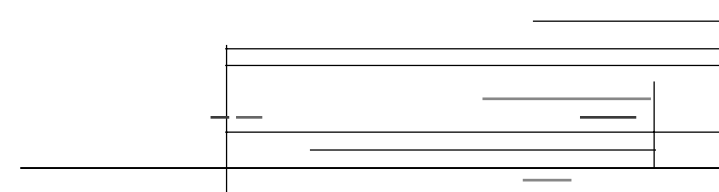
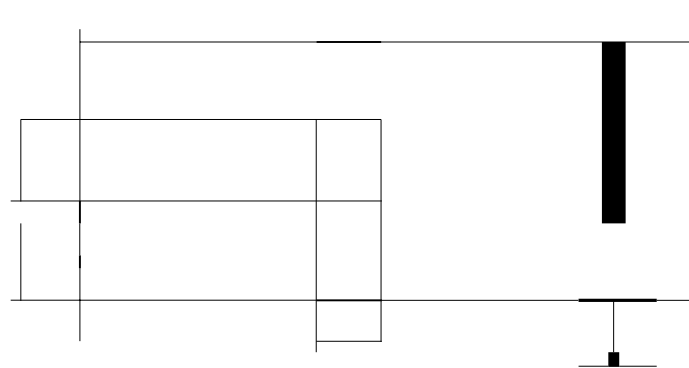
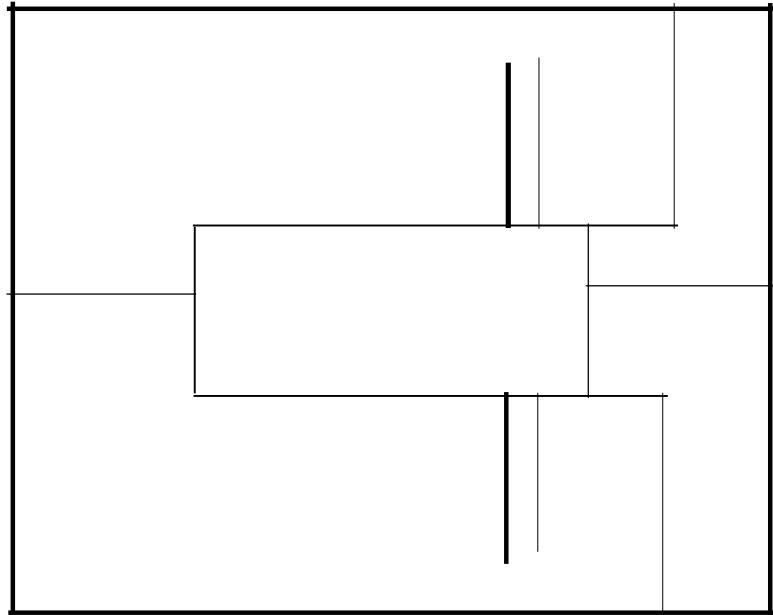
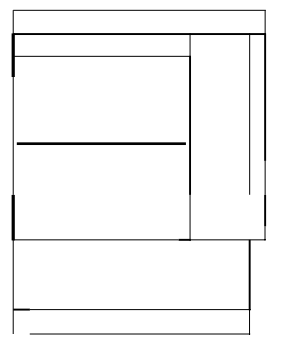
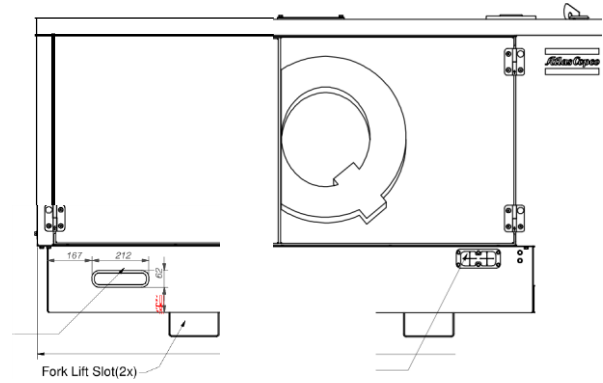
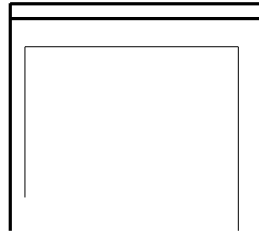
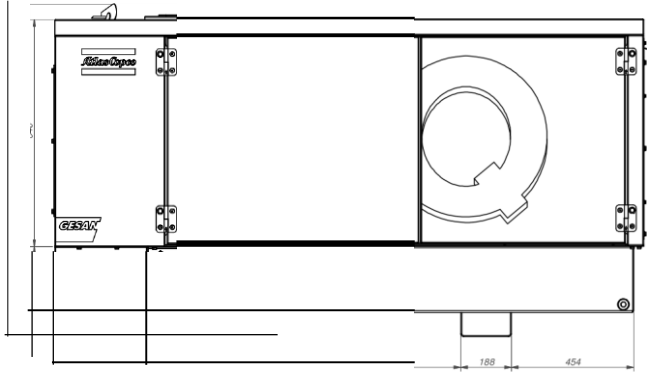

Scale: 1:10
 Approved P III
 Ver.: 1D
 Kgr. no. w1 2287.2 Kg/Designation
 ID: c1 ch 4 sche-c1-901AP9-CV9d dā dā | 2011.00 1636005161

ESF

This document is the property of the client and must be kept confidential. It is not to be distributed outside the project team without the client's written consent.

| | |
|----|--|
| 80 | |
| EQ | |

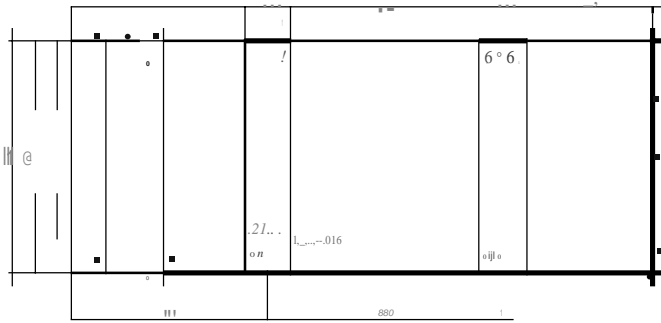

ISOMETRIC VIEW (1 : 20)

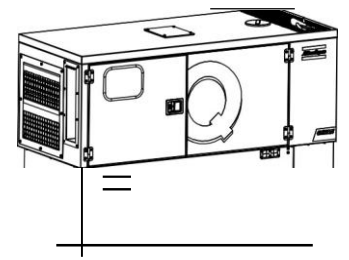

See r.v. ic e Pane l for Clearing Cooler

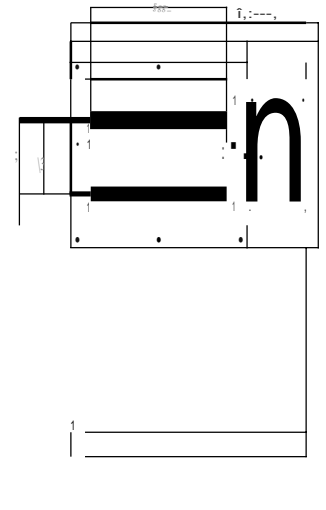
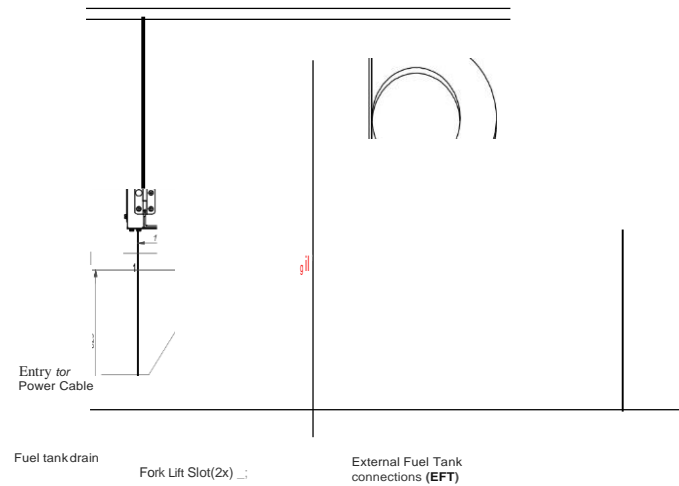
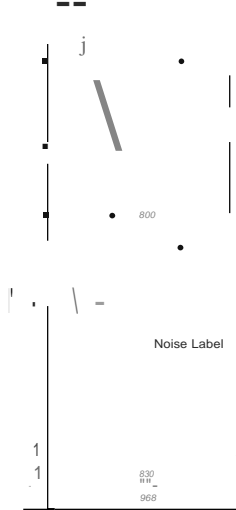
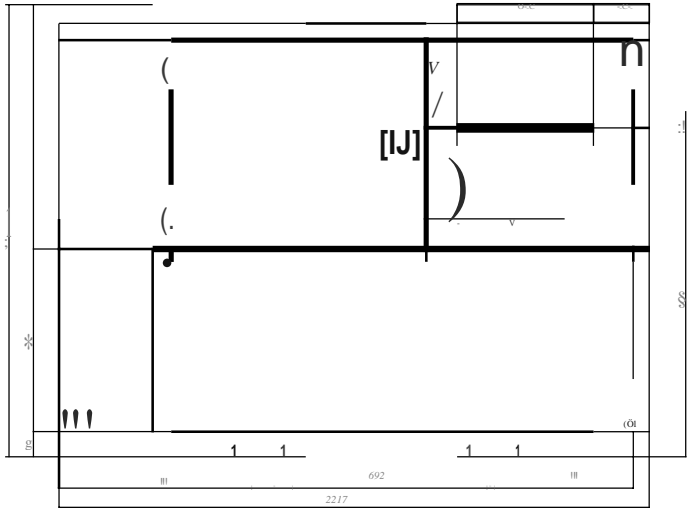

1772 275 35 gl

1

900 250 1050

Cooler

| | | | |
|-----------------------|--|------------------|------|
| MENSIONOR WG | | Q1S BOX A-G14002 | ET-@ |
| Approved By: ESPAR | | 27072 | ESF |
| Approved: [Signature] | | 1636005161 | |

CONFIDENTIAL: This information is for internal use only and is not to be distributed outside of the organization.

G(1:15)

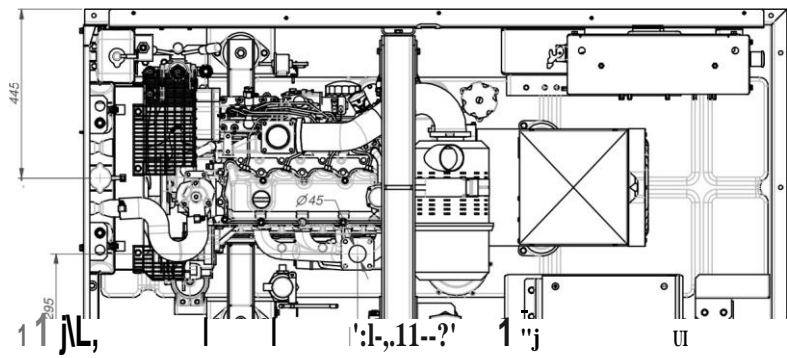
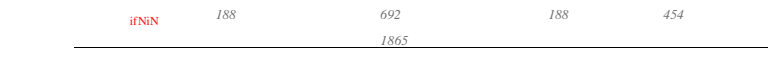
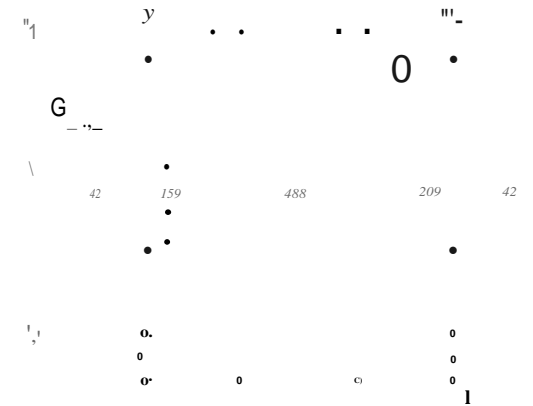
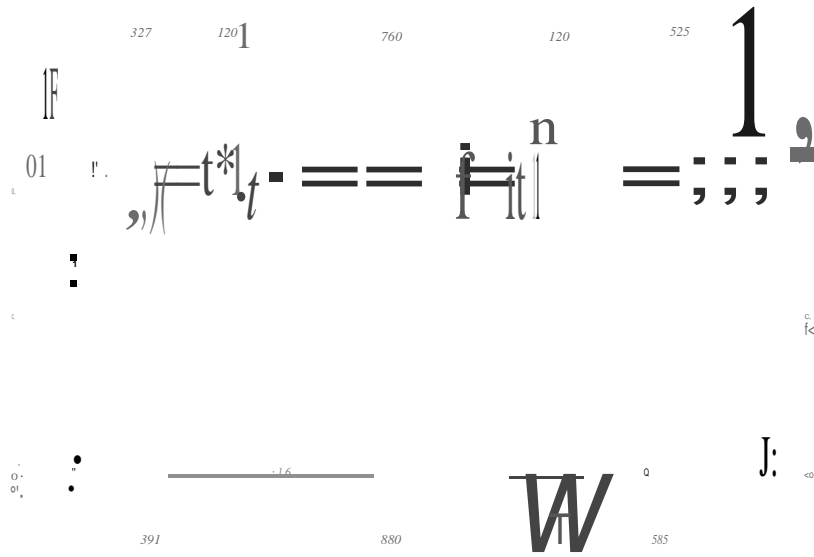

QI 35 Bh

Tolerances, if not indicated, according to: General tolerances 1350K - mK

u un u u, o - u - " 1

ii
Ed. 1.1 = 1.1
gjl
Ed. 1.1 = 1.1
ghim l: r l: : g l

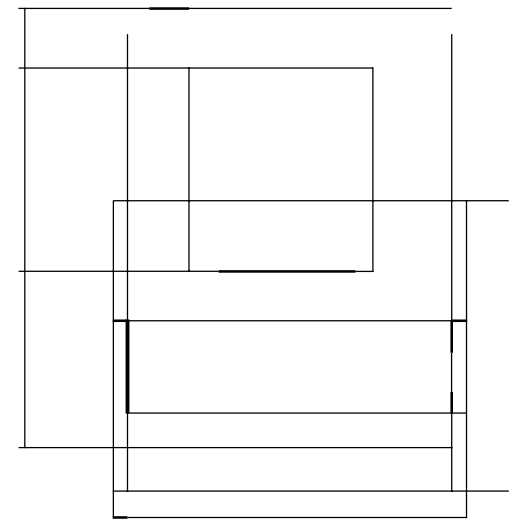
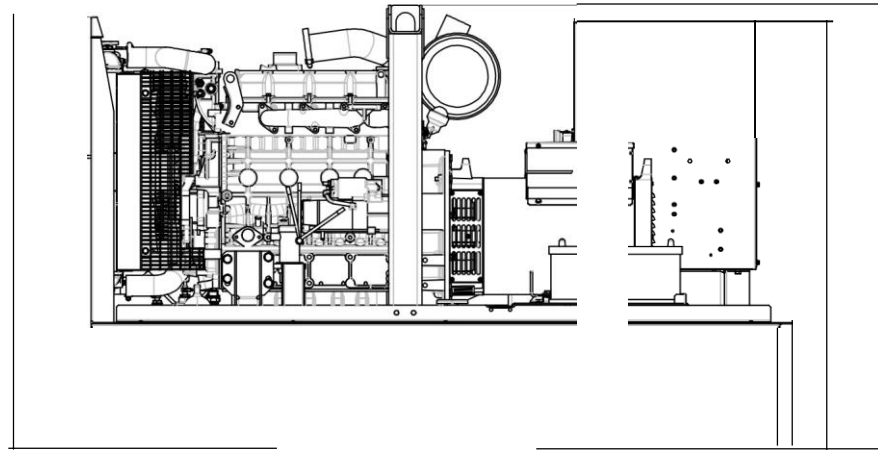
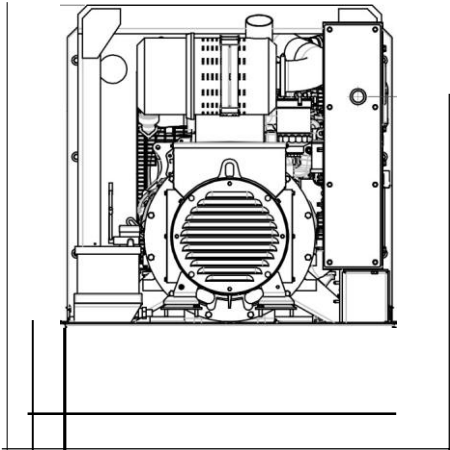
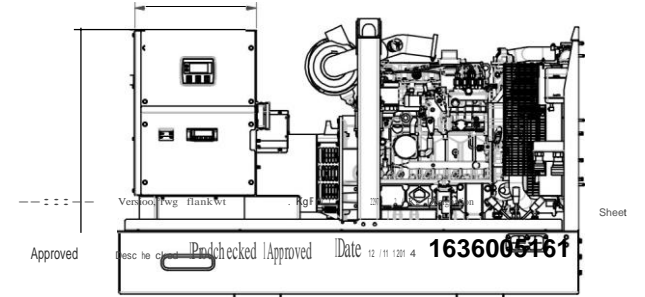
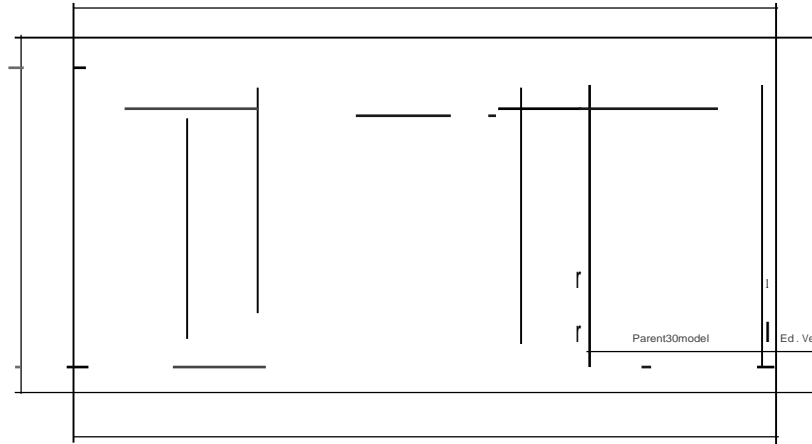

| | |
|--|--|
| | |
| | |
| | |
| | |

K (1 : 15)

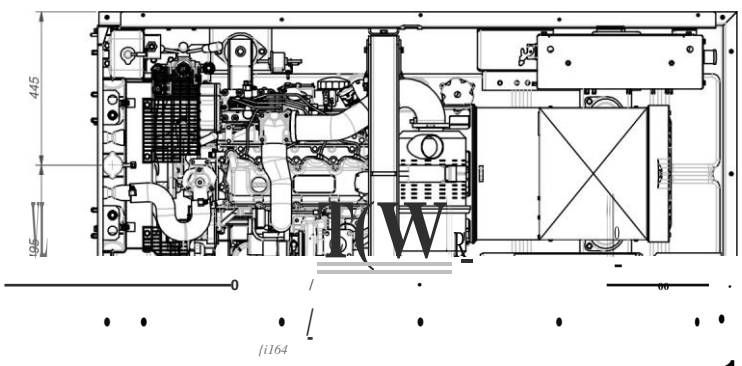
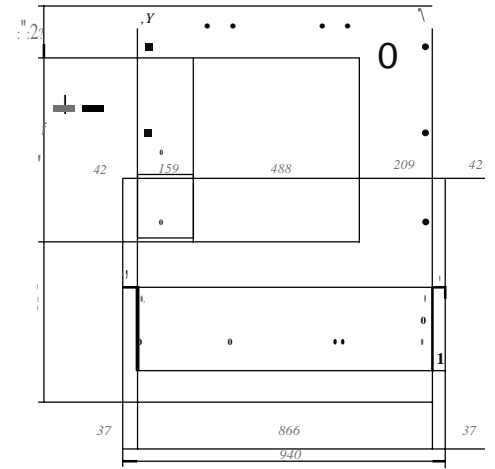
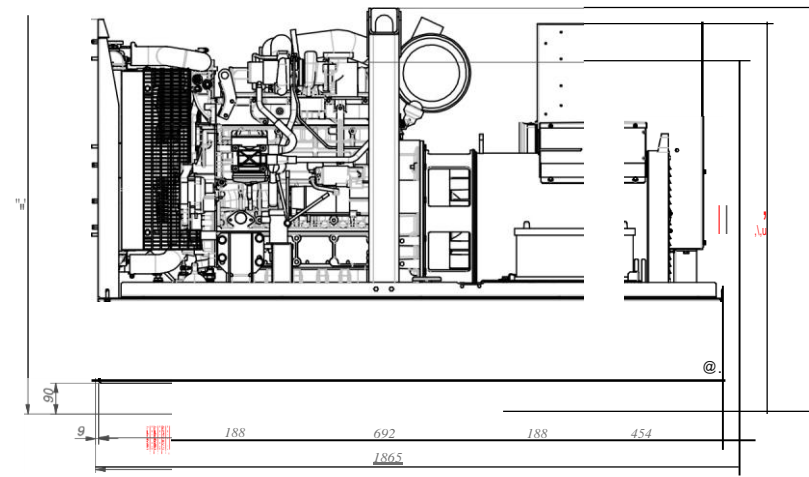
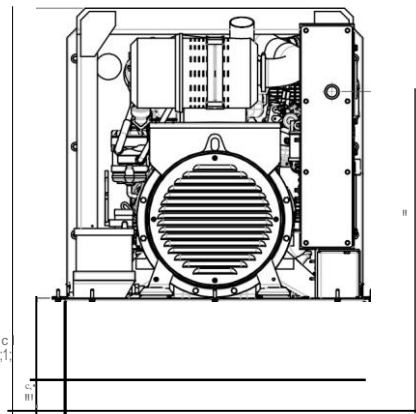
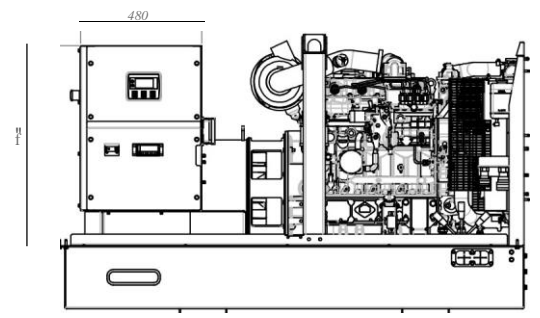
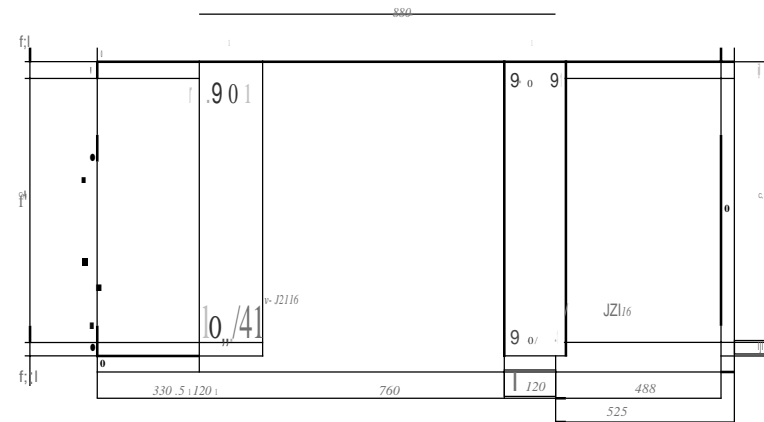

QI 45 Bh

References, if not indicated, according to:

| | | | | | | |
|-----------|---------------|--------------|---------------------|------------------|-----|-------------------|
| Male1.al | Scale | IFamily | A2 Compare | Thickness | INV | Coolo -cia |
| Treatment | Drawnby ESFAR | IBlanknr | - 1 Replaces | | | ESF |
| | Version: Drwg | EIblank wt | KI Fni wt 2297.24 K | Designation | | |
| | Desc te cked | IProdchecked | IApproved | IDate 12/11/2014 | | |
| | | | | | | 1636005161 |

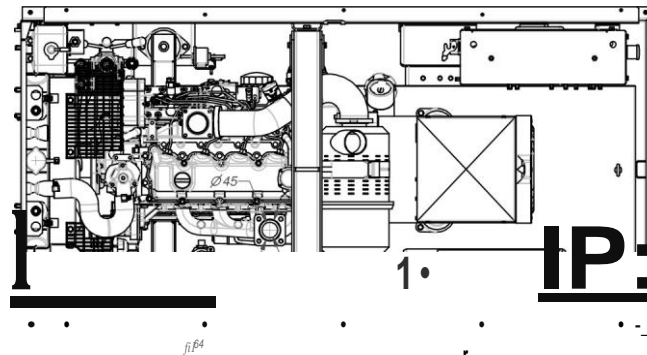
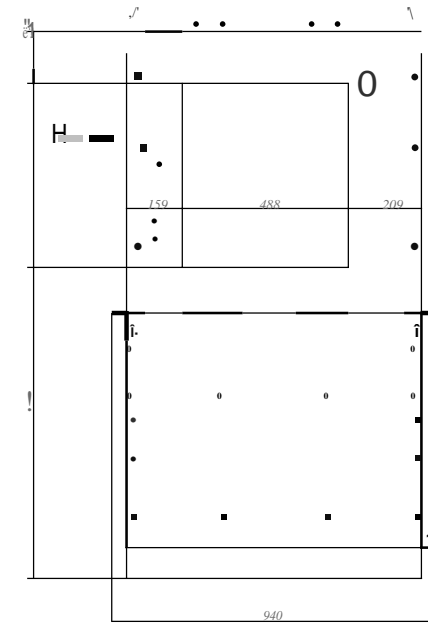
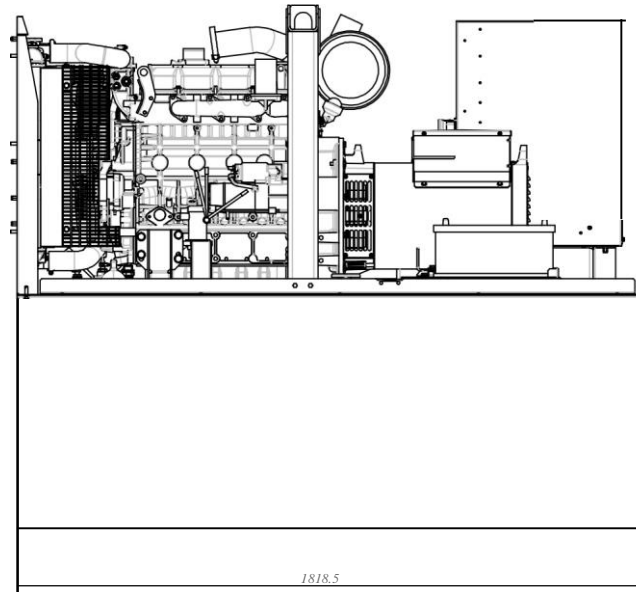
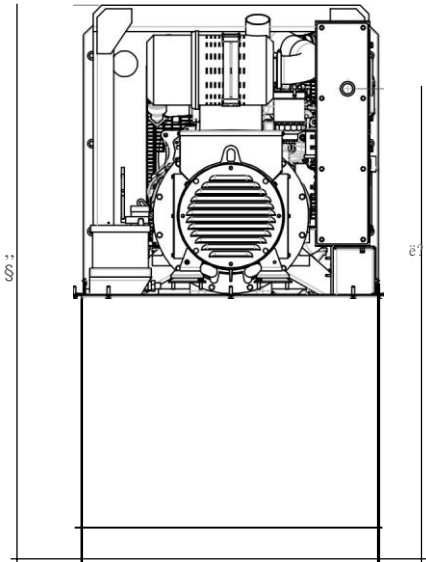
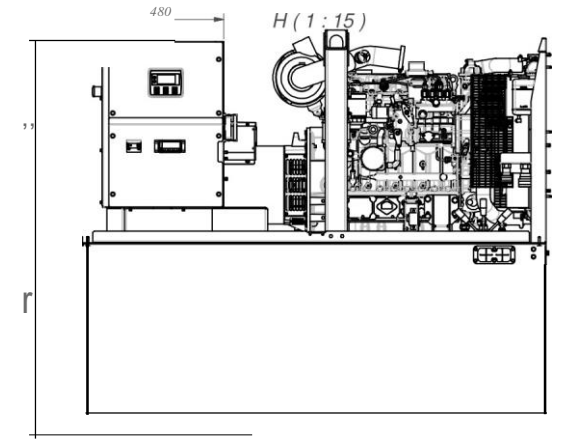
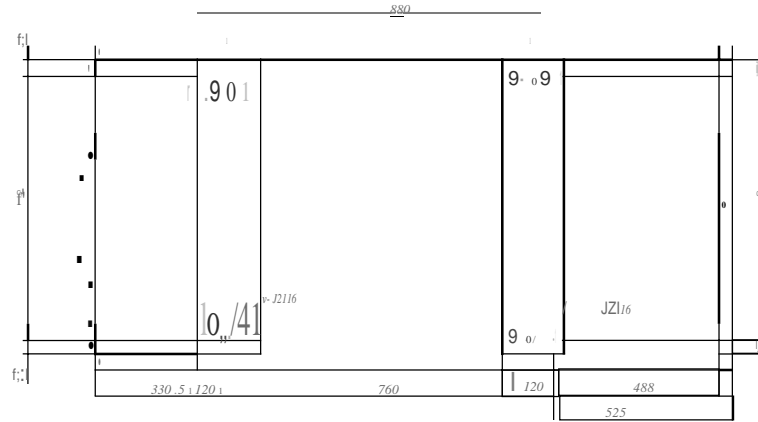

QI3548h

Tolerances, if not indicated, according to:

Thokoess | INV | Drawingowner | ESF
 ..Rtasl-peo | Scale | A2 Compare | ..Rtasl-peo
 Version:rwg | Drawn by | Blankr | KgF n1 | ..Rtasl-peo
 ..Rtasl-peo | Drawn by | Blankr | KgF n1 | ..Rtasl-peo

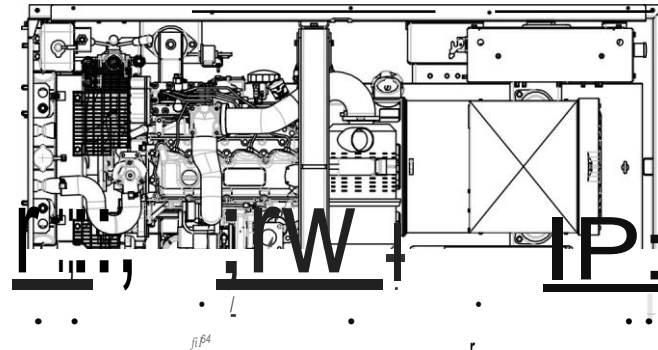
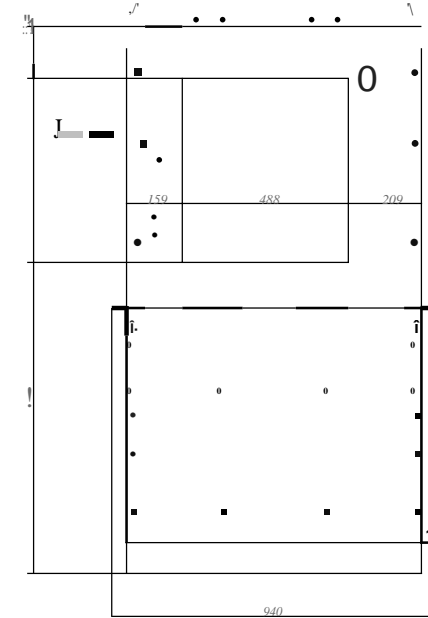
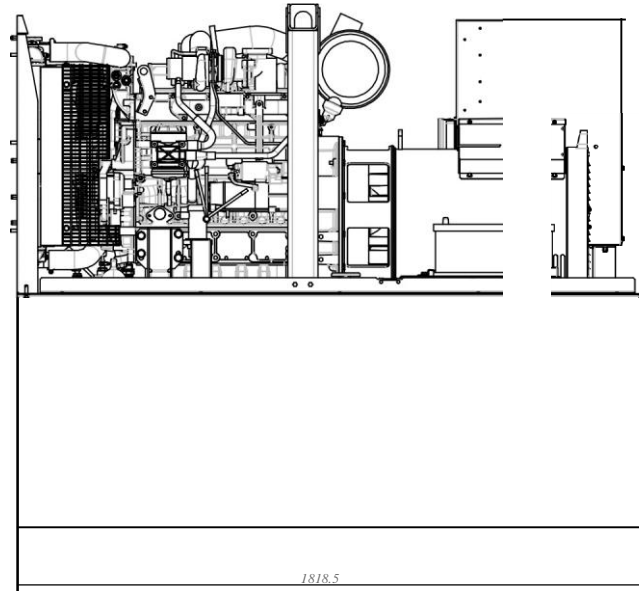
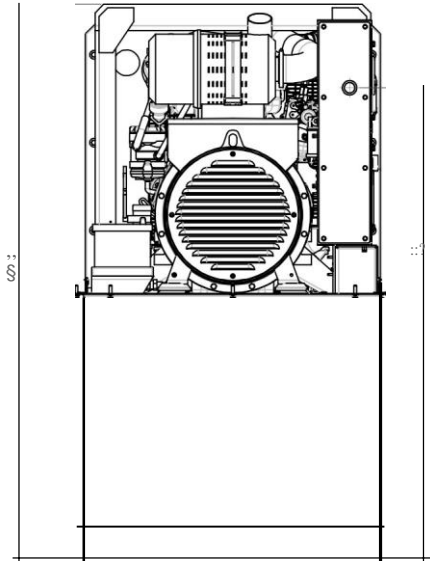
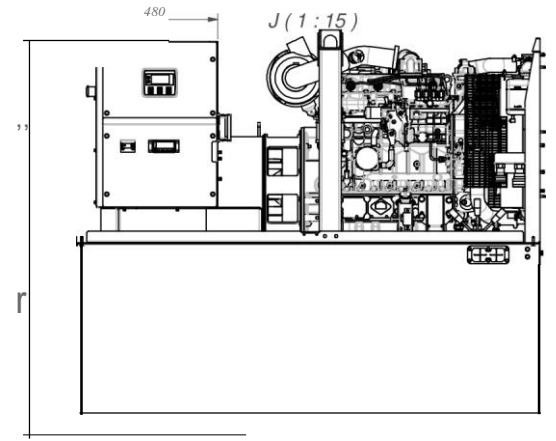
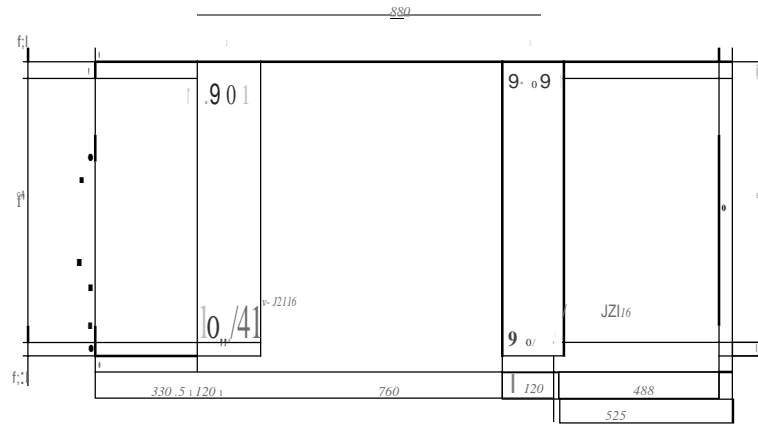

QI 45 48h

Tolerances, if not indicated, according to:

u u u u u u u u u u u u

u,o-A,U u u u u u u u u u u

Scale Drawn by ESFAR Version, rtwg blankwt

Family Blanknr KgFn I Ap æs Designation

Thickness 1 INV

Drawingowner ESF Sheet

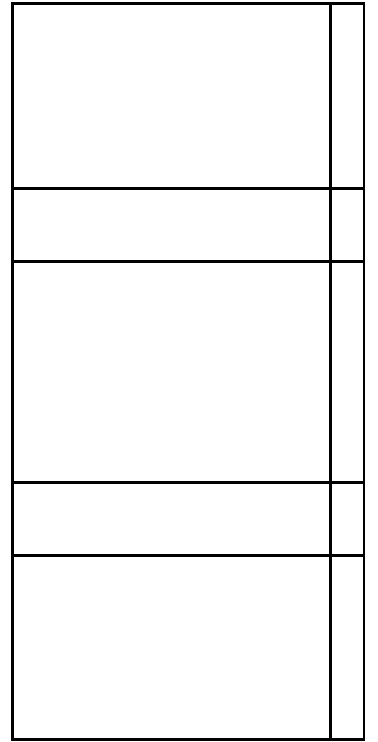
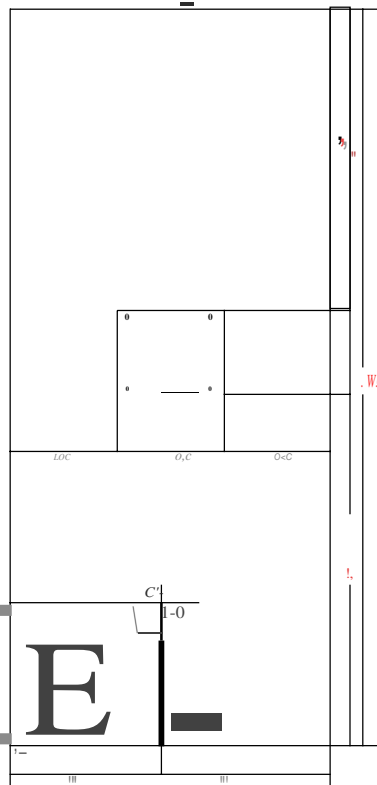
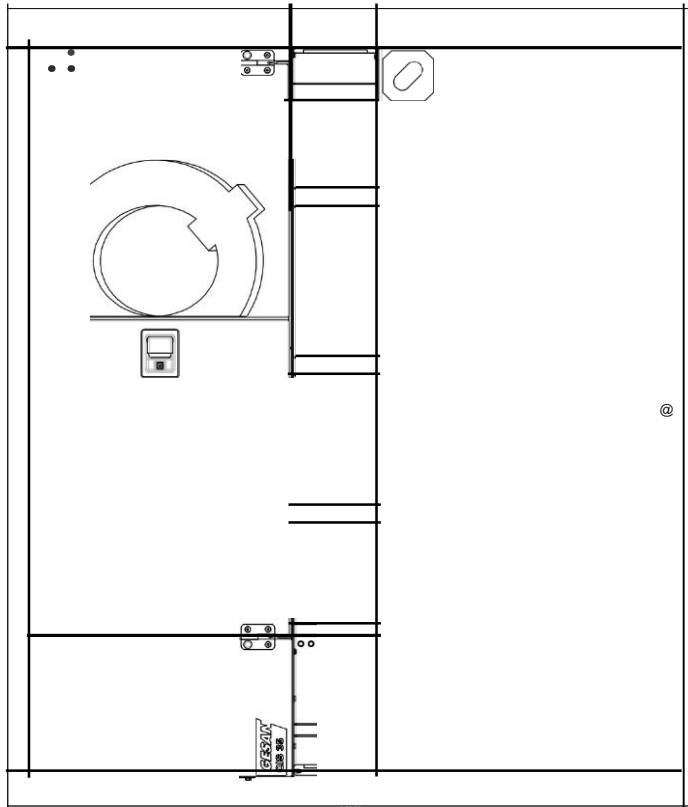
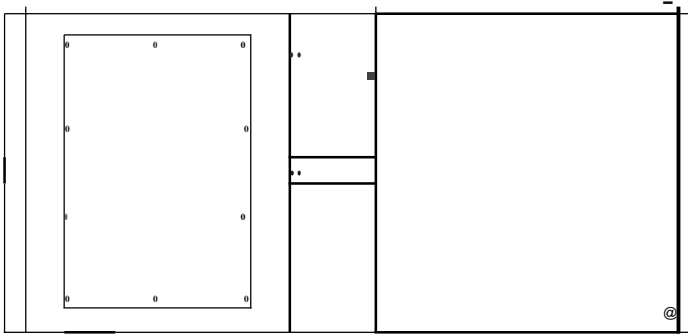
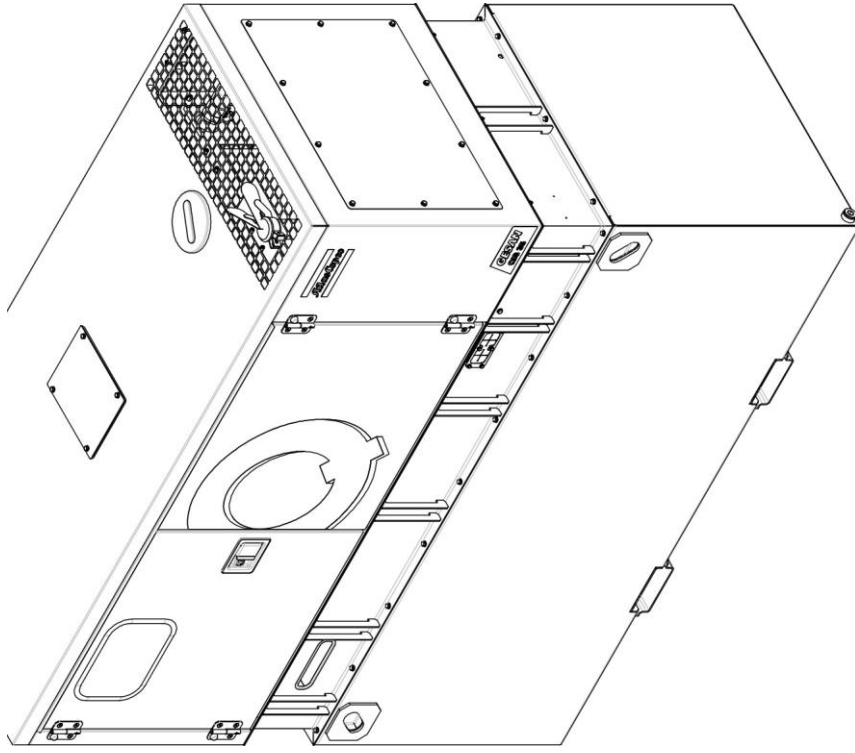

Tolerances, if not indicated, according to:

Name: DIMENSION DRWG

Material: OIS BOX A.G14002

Condition: INV

Drawing name: ESF

Sheet: 1 / 1

Approved: 1636005161

Date: 13/11/2014

Author: [Blank]

Scale: [Blank]

Family: [Blank]

Drawn by: [Blank]

Block no.: [Blank]

Version: [Blank]

Project name: [Blank]

Project no.: [Blank]

Project name: [Blank]

Project no.: [Blank]

Project name: [Blank]

Project no.: [Blank]

Project name: [Blank]

Project no.: [Blank]

Project name: [Blank]

Project no.: [Blank]

Project name: [Blank]

Project no.: [Blank]

Project name: [Blank]